

MOD:XEBC-04EU-E1R



ENGLISH

TECHNICAL DATA

- 01 POWER
- 03 FREQUENCY
- 04 POWER SUPPLY CABLE TYPE
- 05 EXTERNAL Ø OF POWER SUPPLY CABLE
- 06 VOLTAGE / POWER CABLE SECTION / CURRENT

7,35 kW
50 / 60 Hz
H07RN-F
13,96 mm

380-415 V~3PH+N+PE
5G x 2,5 mm²
I1=13 A - I2=9,4 A - I3=9,6 A - In=3,6 A

220-240 V~3PH+PE
5G x 2,5 mm²
I1=20 A - I2=20 A - I3=17 A - In=

220-240 V~1PH+N+PE
3G x 4 mm²
I1=32 A - I2= - I3= - In=

- 10 WATER PRESSURE
- 11 MAX FOOD LOAD
- 13 WATER MAX CONSUMPTION
- 02 NOMINAL HEAT INPUT
- 18 CAVITY DIMENSIONS (W - D - H)
- 20 DEGREE OF PROTECTION IP

150-600 kPa
30 kg
9.8 l/h @ 200 kPa
6,85 kW
716x561x392 mm
IPX4

ITALIANO

- 01 POTENZA
- 03 FREQUENZA
- 04 TIPO DI CAVO ALIMENTAZIONE
- 05 Ø ESTERNO CAVO DI ALIMENTAZIONE
- 06 TENSIONE / SEZIONE CAVI ALIMENTAZIONE / CORRENTE
- 10 PRESSIONE ACQUA
- 11 CARICA MAX CIBO
- 13 CONSUMO MAX ACQUA
- 02 POTENZA TERMICA NOMINALE
- 18 DIMENSIONI CAMERA COTTURA (L - P - H)
- 20 GRADO PROTEZIONE IP

FRANCAIS

- 01 PUISSANCE ELECTRIQUE
- 03 FREQUENCE
- 04 TYPE DE CABLE D'ALIMENTATION
- 05 Ø EXTERNE DU CABLE D'ALIMENTATION
- 06 TENSION / SECTION CABLE D'ALIM.
- 10 PRESSION DE L'EAU
- 11 CHARGE MAXIMALE D'ALIMENT
- 13 CONSOMMATION MAX DE L'EAU
- 02 DEBIT THERMIQUE NOMINAL
- 18 DIMENSIONS CHAMBRE DE COISSON (L - P - A)
- 20 INDICE DE PROTECTION IP

ESPAÑOL

- 01 POTENCIA
- 03 FRECUENCIA
- 04 TIPO DE CABLE DE ALIMENTACION
- 05 Ø CABLE EXTERNO DE ALIMENTACION
- 06 TENSION / SECCION CABLES DE ALIMENTACION
- 10 PRESION AGUA
- 11 CARGA MAX. DE ALIMENTOS
- 13 CONSUMO MAX DE AGUA
- 02 POTENCIA TERMICA NOMINAL
- 18 DIMENSIONES CÁMARA DE COCCIÓN (A - A - P)
- 20 GRADO DE PROTECCION IP

DEUTSCH

- 01 ELEKTRISCHE LEISTUNG
- 03 FREQUENZ
- 04 ZULEITUNGSKABELTYP
- 05 AUSSENDURCHMESSER DES VERSORGUNGSKABELS
- 06 KABELQUERSCHNITT UND VERSORGUNGSSPANNUNG
- 10 WASSERDRUCK
- 11 MAX. SPEISENFASSUNGSVERMOGEN
- 13 MAXIMUM WASSERVERBRAUCH
- 02 NOMINALE WARMELEISTUNG
- 18 GRÖßE DES KOCHKAMMERS (B - T - H)
- 20 SCHTZART IP



MOD:XEBC-04EU-E1R



ENGLISH - DRAWINGS

1	TERMINAL BOARD COVER BOX
2	TERMINAL BOARD POWER SUPPLY
3	UNIPOTENTIAL TERMINAL
6	TECHNICAL DATA PLATE
7	SAFETY THERMOSTAT
8	3/4" THREAD WATER INLET
10	Rotor.KLEAN CONNECTION
11	CAVITY DRAIN PIPE
12	HOT FUMES EXHAUST CHIMNEY
13	ACCESSORIES CONNECTION
27	COOLING AIR OUTLET

ITALIANO - DISEGNI

1	SCATOLA COPRI MORSETTIERA
2	MORSETTIERA ALIMENTAZIONE
3	MORSETTO EQUIPOTENZIALE
6	TARGHETTA DATI TECNICI
7	TERMOSTATO DI SICUREZZA
8	INGRESSO ACQUA 3/4"
10	INGRESSO Rotor.KLEAN
11	SCARICO CAMERA DI COTTURA
12	USCITA FUMI CALDI
13	COLLEGAMENTO ACCESSORI
27	USCITA ARIA DI RAFFREDDAMENTO

FRANCAIS - ENCOMBREMEN

1	CHAUMARD
2	BOITE A BORNES D'ALIMENTATION
3	SUPPORT BORNE EQUIPOTENTIELLE
6	PLAQUETTE SEGNALETIQUE
7	THERMOSTAT DE SECURITE
8	ARRIVE D'EAU FIETL 3/4"
10	ENTREE Rotor.KLEAN
11	SORTIE DE L'EAU RACCORD
12	SORTIE DES FUMEEES CHAUDES
13	JONCTION DES ACCESSOIRES
27	SORTIE D'EAU DE REFROIDISSEMENT

ESPAÑOL - DISEÑOS

1	PASA CABLE
2	CAJA DE CONEXION
3	SEDE BORNE EQUIPOTENCIAL
6	TARJETA DE CARACTERISTICAS TECNICAS
7	TERMOSTATO DE SEGURIDAD
8	ENTRADA DE AGUA 3/4"
10	INGRESO Rotor.KLEAN
11	DESCARGA CAMARA DE COCCION
12	SALIDA HUMOS CALIENTES
13	CONEXION ACCESORIOS
27	SALIDA DEL AIRE DE ENFRIAMIENTO

DEUTSCH - ZEICHNUNGEN

1	KLEMMLEISTEANSCHLUSS
2	ZULEITUNGSKLEMMLEISTE
3	GLEICHPOTENTIELLE KLAMMER
6	TYPENSCHILD
7	SICHERHEITSTHERMOSTAT
8	WASSEREINZUG 3/4" GEWINDE
10	Rotor.KLEAN EINGANG
11	WASSERAUSLASS GEWINDE
12	ABZUGSHAUBE
13	ZUBEHÖRTEILENVERBINDUNG
27	KÜHLLUFTAUSTRITT

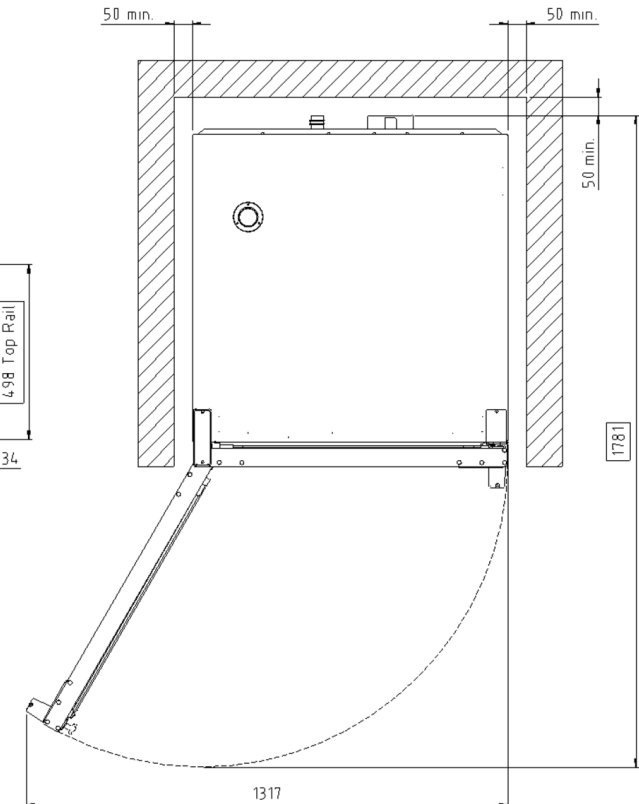
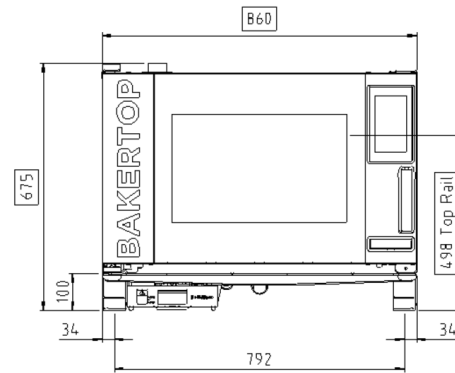
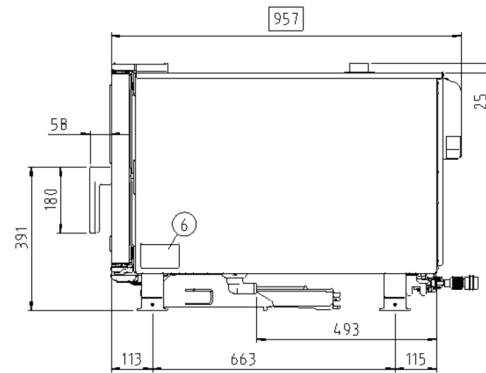
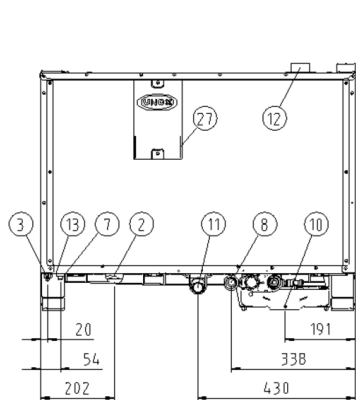

MOD:XEBC-04EU-E1R

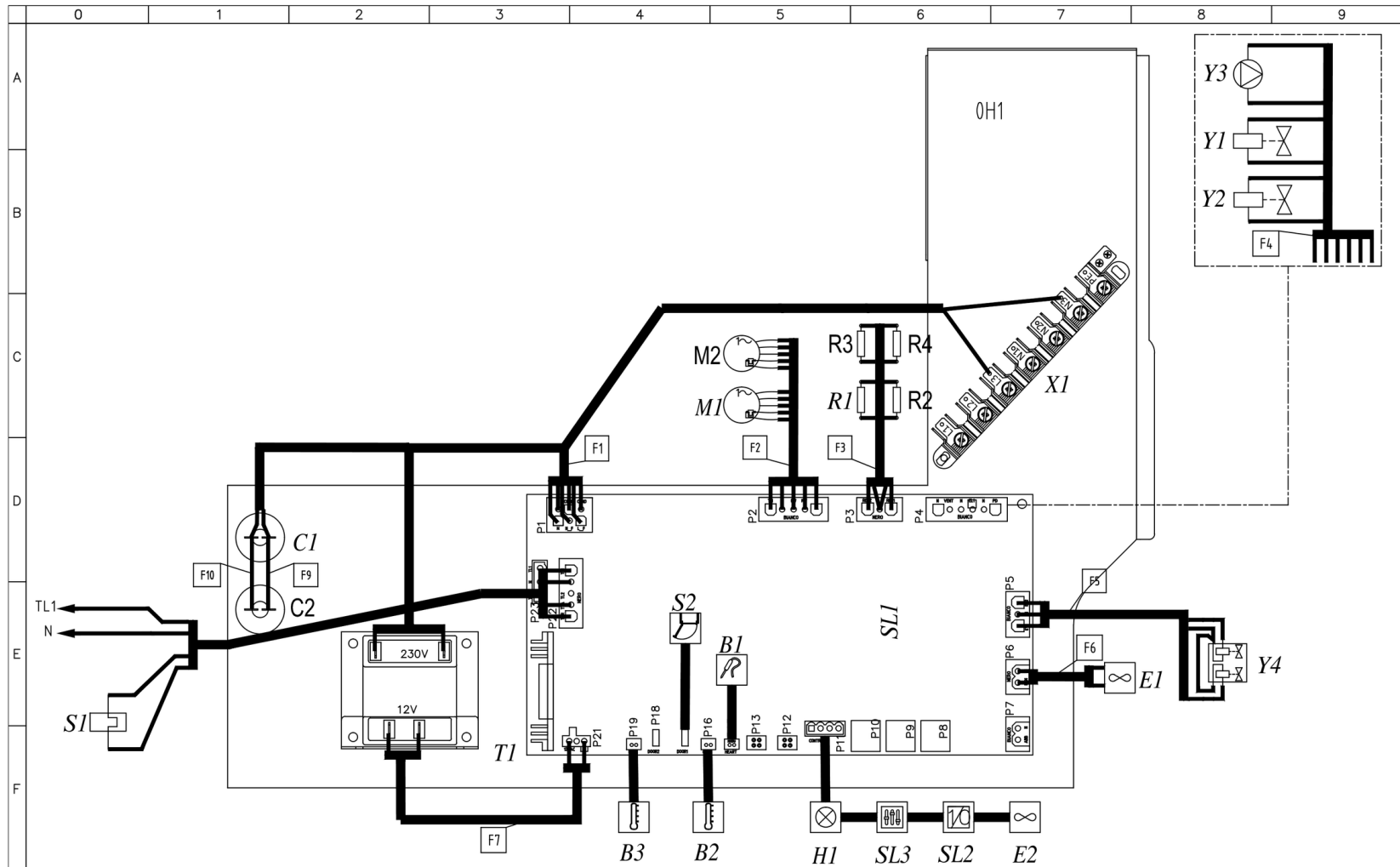

MOD:XEBC-04EU-E1R

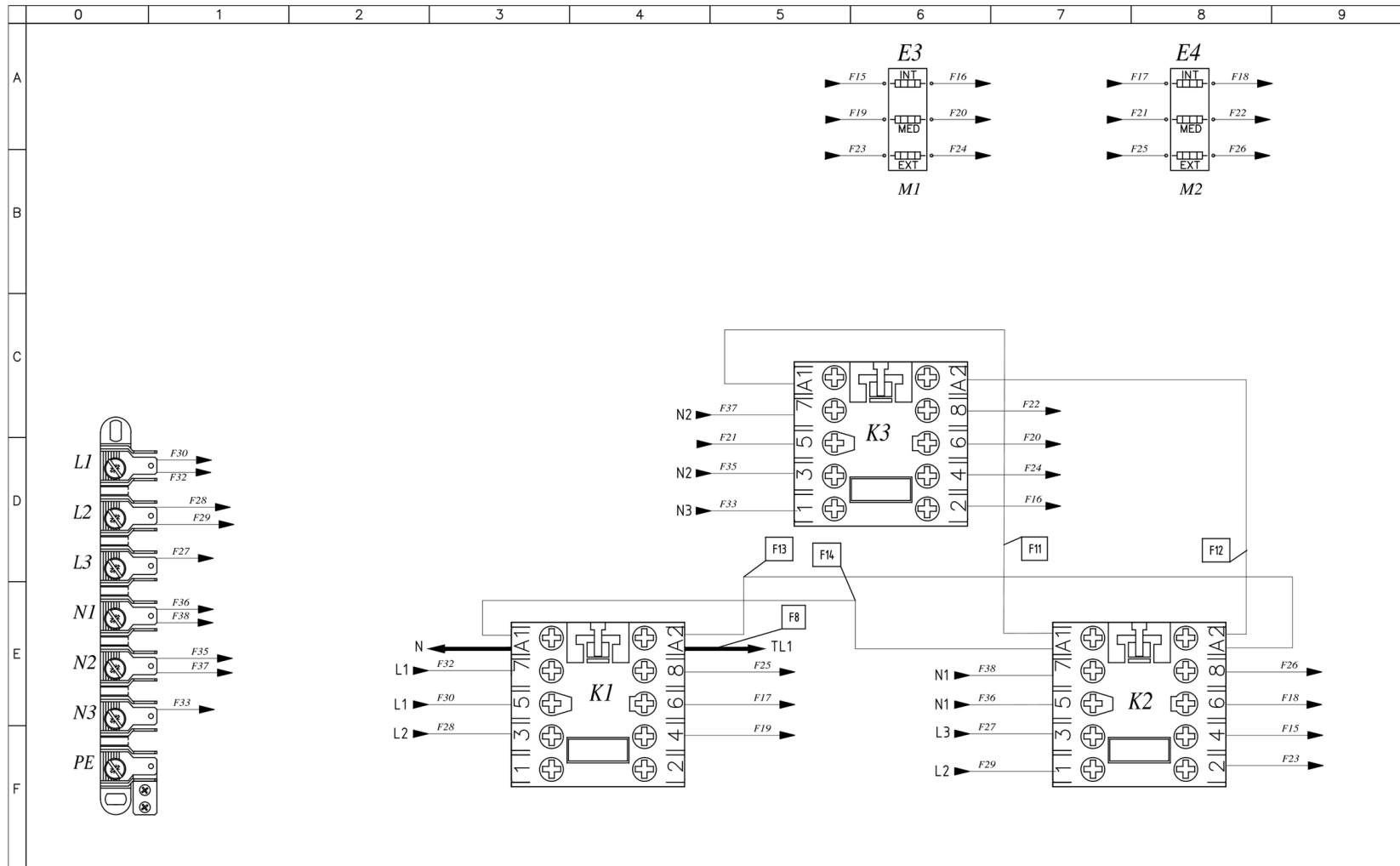

MOD:XEBC-04EU-E1R



	0	1	2	3	4	5	6	7	8	9																																																																																																																															
A																																																																																																																																									
B																																																																																																																																									
C	<table border="1"> <thead> <tr> <th>Sigle</th> <th>ITALIANO</th> <th>ENGLISH</th> <th>FRANCAIS</th> <th>ESPA?OL</th> <th>DEUTSCH</th> </tr> </thead> <tbody> <tr> <td>B1</td> <td>SONDA AL CUORE</td> <td>CORE PROBE</td> <td>SONDE A COEUR</td> <td>SONDA CORAZON</td> <td>KERNTEMPERATURFUHLER</td> </tr> <tr> <td>B2,B3</td> <td>SONDA CAMERA</td> <td>TEMPERATURE PROBE</td> <td>SONDE DE CHAMBRE</td> <td>SONDA CAMARA</td> <td>GARRAUMTEMPERATURFUHLER</td> </tr> <tr> <td>C1,C2</td> <td>CONDENSATORE</td> <td>MOTOR CAPACITOR</td> <td>CONDENSATEUR</td> <td>CONDENSADOR</td> <td>KONDENSATOR</td> </tr> <tr> <td>E1,E2</td> <td>VENTOLA RAFFREDDAMENTO</td> <td>COOLING FAN</td> <td>TURBINE DE REFROIDISSEMENT</td> <td>TURBINA DE REFRIGERACION</td> <td>LUEFTER</td> </tr> <tr> <td>E3,E4</td> <td>ELEMENTO RISCALDANTE</td> <td>HEATING ELEMENT</td> <td>ELEMENT DE CHAUFFAGE</td> <td>RESISTENCIA DE CALEFACCION</td> <td>HEIZUNG</td> </tr> <tr> <td>H1</td> <td>LUCE CAMERA</td> <td>OVEN LIGHT</td> <td>ECLAIRAGE DE CHAMBRE</td> <td>LUZ CAMARA</td> <td>BELEUCHTUNG</td> </tr> <tr> <td>K1,K2,K3</td> <td>TELERUTTORE</td> <td>CONTACTOR</td> <td>TELERUPTEUR</td> <td>TELERRUPTOR</td> <td>RELAIS</td> </tr> <tr> <td>M1,M2</td> <td>MOTORE</td> <td>MOTOR</td> <td>MOTEUR</td> <td>MOTOR</td> <td>MOTOR</td> </tr> <tr> <td>R1,R2,R3,R4</td> <td>RESISTENZA DI MODULAZIONE VENTILATORE</td> <td>MOTOR MODULATION RESISTANCE</td> <td>RESISTANCE DE MODULATION VENTILATEUR</td> <td>RESISTENCIA MODULACION VELOCIDAD</td> <td>WIDERSTAND LOW FAN</td> </tr> <tr> <td>S1</td> <td>TERMOSTATO SICUREZZA</td> <td>SAFETY THERMOSTAT</td> <td>THERMOSTAT DE SECURITE</td> <td>TERMOSTATO DE SEGURIDAD</td> <td>SICHERHEITS THERMOSTAT</td> </tr> <tr> <td>S2</td> <td>MICRO INTERRUPTORE PORTA</td> <td>DOOR MICROSWITCH</td> <td>MICROINTERRUPTEUR DE PORTE</td> <td>MICROINTERRUPTOR PUERTA</td> <td>TURKONTAKTSCHALTER</td> </tr> <tr> <td>SL1</td> <td>SCHEDA POTENZA</td> <td>POWER CARD</td> <td>CARTE DE PUISSANCE</td> <td>TARJETA POTENCIA</td> <td>POWERPLATINE</td> </tr> <tr> <td>SL2</td> <td>SCHEDA 1/0 – USB</td> <td>USB – 1/0 BOARD</td> <td>USB – CARTE 1/0</td> <td>USB – TARJETA 1/0</td> <td>USB – 1/0 PLATINE</td> </tr> <tr> <td>SL3</td> <td>SCHEDA CONTROLLO</td> <td>CONTROL BOARD</td> <td>CARTE DE CONTROLE</td> <td>TARJETA DE CONTROL</td> <td>KONTROLL PLATINE</td> </tr> <tr> <td>T1</td> <td>TRASFORMATORE</td> <td>TRANSFORMER</td> <td>TRASFORMATEUR</td> <td>TRANSFORMADOR</td> <td>TRASFORMATORE</td> </tr> <tr> <td>X1</td> <td>MORSETTIERA</td> <td>CONTACTOR</td> <td>BORNIER</td> <td>CONECTOR</td> <td>KLEMMLEISTE</td> </tr> <tr> <td>Y1</td> <td>ELETTROVALVOLA ACQUA</td> <td>WATER SOLENOID VALVE</td> <td>ELECTROVANNE EAU</td> <td>ELECTROVALVULA</td> <td>ELEKTROVENTIL</td> </tr> <tr> <td>Y2</td> <td>DRY MAXY</td> <td>DRY MAXY</td> <td>DRY MAXY</td> <td>DRY MAXY</td> <td>DRY MAXY</td> </tr> <tr> <td>Y3</td> <td>POMPA</td> <td>PUMP</td> <td>POMPE</td> <td>BOMBA</td> <td>PUMPE</td> </tr> <tr> <td>Y4</td> <td>ELETTROVALVOLA ACQUA</td> <td>WATER SOLENOID VALVE</td> <td>ELECTROVANNE EAU</td> <td>ELECTROVALVULA</td> <td>ELEKTROVENTIL</td> </tr> </tbody> </table>	Sigle	ITALIANO	ENGLISH	FRANCAIS	ESPA?OL	DEUTSCH	B1	SONDA AL CUORE	CORE PROBE	SONDE A COEUR	SONDA CORAZON	KERNTEMPERATURFUHLER	B2,B3	SONDA CAMERA	TEMPERATURE PROBE	SONDE DE CHAMBRE	SONDA CAMARA	GARRAUMTEMPERATURFUHLER	C1,C2	CONDENSATORE	MOTOR CAPACITOR	CONDENSATEUR	CONDENSADOR	KONDENSATOR	E1,E2	VENTOLA RAFFREDDAMENTO	COOLING FAN	TURBINE DE REFROIDISSEMENT	TURBINA DE REFRIGERACION	LUEFTER	E3,E4	ELEMENTO RISCALDANTE	HEATING ELEMENT	ELEMENT DE CHAUFFAGE	RESISTENCIA DE CALEFACCION	HEIZUNG	H1	LUCE CAMERA	OVEN LIGHT	ECLAIRAGE DE CHAMBRE	LUZ CAMARA	BELEUCHTUNG	K1,K2,K3	TELERUTTORE	CONTACTOR	TELERUPTEUR	TELERRUPTOR	RELAIS	M1,M2	MOTORE	MOTOR	MOTEUR	MOTOR	MOTOR	R1,R2,R3,R4	RESISTENZA DI MODULAZIONE VENTILATORE	MOTOR MODULATION RESISTANCE	RESISTANCE DE MODULATION VENTILATEUR	RESISTENCIA MODULACION VELOCIDAD	WIDERSTAND LOW FAN	S1	TERMOSTATO SICUREZZA	SAFETY THERMOSTAT	THERMOSTAT DE SECURITE	TERMOSTATO DE SEGURIDAD	SICHERHEITS THERMOSTAT	S2	MICRO INTERRUPTORE PORTA	DOOR MICROSWITCH	MICROINTERRUPTEUR DE PORTE	MICROINTERRUPTOR PUERTA	TURKONTAKTSCHALTER	SL1	SCHEDA POTENZA	POWER CARD	CARTE DE PUISSANCE	TARJETA POTENCIA	POWERPLATINE	SL2	SCHEDA 1/0 – USB	USB – 1/0 BOARD	USB – CARTE 1/0	USB – TARJETA 1/0	USB – 1/0 PLATINE	SL3	SCHEDA CONTROLLO	CONTROL BOARD	CARTE DE CONTROLE	TARJETA DE CONTROL	KONTROLL PLATINE	T1	TRASFORMATORE	TRANSFORMER	TRASFORMATEUR	TRANSFORMADOR	TRASFORMATORE	X1	MORSETTIERA	CONTACTOR	BORNIER	CONECTOR	KLEMMLEISTE	Y1	ELETTROVALVOLA ACQUA	WATER SOLENOID VALVE	ELECTROVANNE EAU	ELECTROVALVULA	ELEKTROVENTIL	Y2	DRY MAXY	DRY MAXY	DRY MAXY	DRY MAXY	DRY MAXY	Y3	POMPA	PUMP	POMPE	BOMBA	PUMPE	Y4	ELETTROVALVOLA ACQUA	WATER SOLENOID VALVE	ELECTROVANNE EAU	ELECTROVALVULA	ELEKTROVENTIL										
Sigle	ITALIANO	ENGLISH	FRANCAIS	ESPA?OL	DEUTSCH																																																																																																																																				
B1	SONDA AL CUORE	CORE PROBE	SONDE A COEUR	SONDA CORAZON	KERNTEMPERATURFUHLER																																																																																																																																				
B2,B3	SONDA CAMERA	TEMPERATURE PROBE	SONDE DE CHAMBRE	SONDA CAMARA	GARRAUMTEMPERATURFUHLER																																																																																																																																				
C1,C2	CONDENSATORE	MOTOR CAPACITOR	CONDENSATEUR	CONDENSADOR	KONDENSATOR																																																																																																																																				
E1,E2	VENTOLA RAFFREDDAMENTO	COOLING FAN	TURBINE DE REFROIDISSEMENT	TURBINA DE REFRIGERACION	LUEFTER																																																																																																																																				
E3,E4	ELEMENTO RISCALDANTE	HEATING ELEMENT	ELEMENT DE CHAUFFAGE	RESISTENCIA DE CALEFACCION	HEIZUNG																																																																																																																																				
H1	LUCE CAMERA	OVEN LIGHT	ECLAIRAGE DE CHAMBRE	LUZ CAMARA	BELEUCHTUNG																																																																																																																																				
K1,K2,K3	TELERUTTORE	CONTACTOR	TELERUPTEUR	TELERRUPTOR	RELAIS																																																																																																																																				
M1,M2	MOTORE	MOTOR	MOTEUR	MOTOR	MOTOR																																																																																																																																				
R1,R2,R3,R4	RESISTENZA DI MODULAZIONE VENTILATORE	MOTOR MODULATION RESISTANCE	RESISTANCE DE MODULATION VENTILATEUR	RESISTENCIA MODULACION VELOCIDAD	WIDERSTAND LOW FAN																																																																																																																																				
S1	TERMOSTATO SICUREZZA	SAFETY THERMOSTAT	THERMOSTAT DE SECURITE	TERMOSTATO DE SEGURIDAD	SICHERHEITS THERMOSTAT																																																																																																																																				
S2	MICRO INTERRUPTORE PORTA	DOOR MICROSWITCH	MICROINTERRUPTEUR DE PORTE	MICROINTERRUPTOR PUERTA	TURKONTAKTSCHALTER																																																																																																																																				
SL1	SCHEDA POTENZA	POWER CARD	CARTE DE PUISSANCE	TARJETA POTENCIA	POWERPLATINE																																																																																																																																				
SL2	SCHEDA 1/0 – USB	USB – 1/0 BOARD	USB – CARTE 1/0	USB – TARJETA 1/0	USB – 1/0 PLATINE																																																																																																																																				
SL3	SCHEDA CONTROLLO	CONTROL BOARD	CARTE DE CONTROLE	TARJETA DE CONTROL	KONTROLL PLATINE																																																																																																																																				
T1	TRASFORMATORE	TRANSFORMER	TRASFORMATEUR	TRANSFORMADOR	TRASFORMATORE																																																																																																																																				
X1	MORSETTIERA	CONTACTOR	BORNIER	CONECTOR	KLEMMLEISTE																																																																																																																																				
Y1	ELETTROVALVOLA ACQUA	WATER SOLENOID VALVE	ELECTROVANNE EAU	ELECTROVALVULA	ELEKTROVENTIL																																																																																																																																				
Y2	DRY MAXY	DRY MAXY	DRY MAXY	DRY MAXY	DRY MAXY																																																																																																																																				
Y3	POMPA	PUMP	POMPE	BOMBA	PUMPE																																																																																																																																				
Y4	ELETTROVALVOLA ACQUA	WATER SOLENOID VALVE	ELECTROVANNE EAU	ELECTROVALVULA	ELEKTROVENTIL																																																																																																																																				
D																																																																																																																																									
E																																																																																																																																									
F																																																																																																																																									